

CUSTOMER PART No.

CUSTOMER

**CAN ART STD.**

DIE No.

**EH05609**

DESCRIPTION

1-1/2" x 1-1/2" x .061" SQ. TUBE w/ RADS

PROPOSAL No.

H-7998

NOTE: BREAK ALL CORNERS WITH 0.015" (.38 MM) RADIUS UNLESS OTHERWISE NOTED. STANDARD TOLERANCES TO APPLY UNLESS OTHERWISE SPECIFIED.

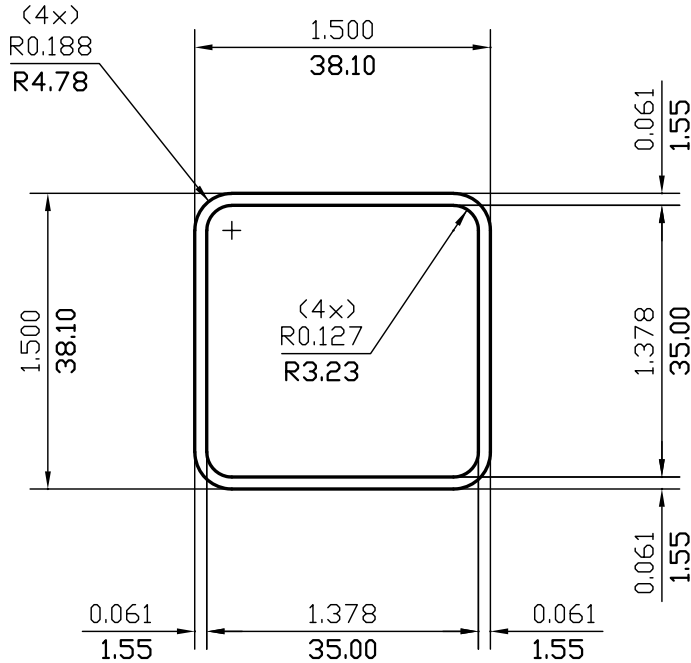

WALL THICKNESS 0.061 (1.55) EXCEPT AS SHOWN

DATE	REV	DESCRIPTION	BY
03/13/23	3	REMOVED ALLOY	JASON
07/26/12	2	REMOVED WALL THICKNESS TOLERANCE.	P.M.
EST.AREA	0.335	IN. <sup>2</sup>	EST.AREA 215.886
			MM. <sup>2</sup>
EST.WT.	0.402	LBS/FT.	EST.WT. 0.598
			KG/M.
EST.PER.	10.971	IN.	EST.PER. 278.669
			MM.
OUT PER.	5.677	IN.	OUT PER. 144.2
			MM.
C.C.D.	1.966	IN.	C.C.D. 49.926
			MM.
FACTOR	27	FINISH M/F	ALLOY & TEMP.
CKD BY	SCALE 1:1	DWN BY C.P.	DATE 09/03/98

**CAN ART**

ALUMINUM EXTRUSION INC.

85 PARKSHORE DRIVE  
BRAMPTON, ONT L6T 5M1  
TEL. NO. (905) 791-1464  
FAX NO. (905) 791-9151  
E-MAIL: canart@canart.com

THIS DRAWING IS NOT NECESSARILY A COPY OF YOUR ORIGINAL. PLEASE APPROVE DIMENSIONS AND TOLERANCES INDICATED. CAN ART ASSUMES NO RESPONSIBILITY EITHER TECHNICAL OR LEGAL FOR HAVING THIS SHAPE MADE. THE CUSTOMER AGREES TO FULLY PROTECT CAN ART ALUMINUM FROM CLAIMS OF OTHERS RESULTING FROM THIS SHAPE.

SIGNED: \_\_\_\_\_ DATE: \_\_\_\_\_